

INVA

THREE WAY VACUUM AND VACUUM-BRAKER TO BE USED WITH PUMPS, DIVERTER VALVE FOR USE WITH BLOWERS

Max fluid temperature: +100°C

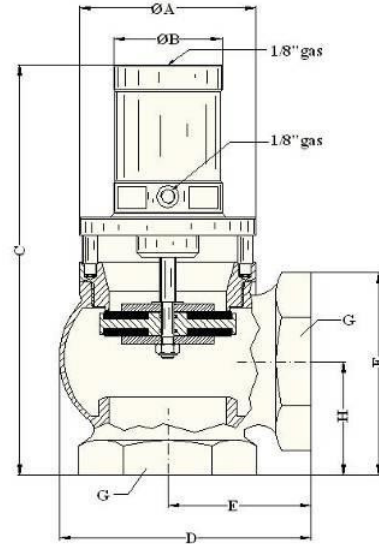

Sizes	1"1/4 – 4" (PN16)
Pipe threads	F/F gas ISO228
Angle	Not
Right-angled	Yes
Normally closed (NC)	Not
Normally open (NO)	Not
Double acting (DA)	Yes cod. 63.....
Ambient temperature	0° / +60°C
Pilot pressure	Min 4 bar – Max 8 bar
Valve body	Bronze
Spacer	Anodized aluminium
Rotable cylinder	Yes (only when ordering)
Seal holder	Brass 1"1/4 - 2", Anodized aluminium 3" - 4"
Piston	Aluminium
Cylinder	Anodized aluminium
Piston rod	Stainless steel Aisi 304
Rod wiper	Ptfe
Rod guide	Special technopolymer self lubricated
Internal o-ring	Fkm
Shutter seal	Fkm 1"1/4 - 2, Nbr 3" – 4" (on request Ptfe, Epdm)

On request:

Atex certification	Yes
Switch box	Two reed sensors



INVA DA

Code	Gas pipe thread	DN	A	B	C	D	E	F	H	Min. absolute pressure [mbar]	Kv (2) [m ³ /h]
63114	1"1/4	32	90	60	190	88	57	74	44	5	21.4
63200	2"	50	90	60	212	123	75	100	60		50.2
63300/N	3"	80	114	70	265	162	93	131	73		156.9
63400	4"	100	134	70	292	177	110	152	84		256.7

Example of application with vacuum pump

modalità vuoto
vacuum mode

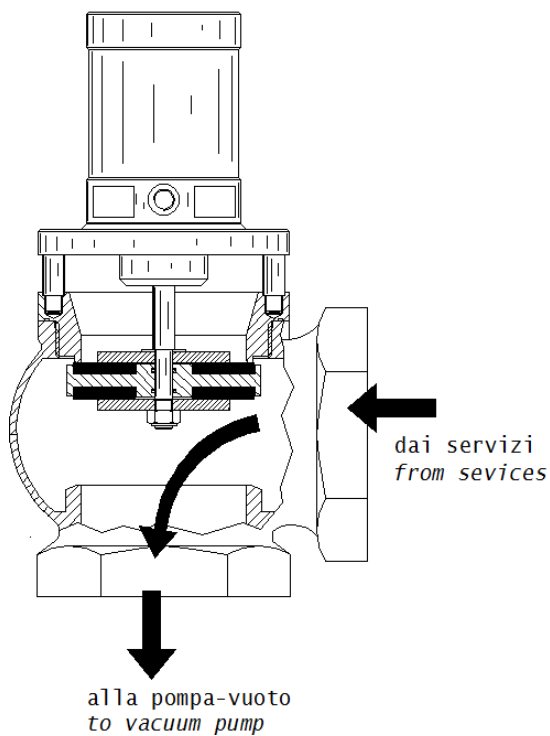

modalità rompi-vuoto
vacuum-breaking mode

